

### TECHNICAL INFORMATION

This technical information describes the GT-5000 mechanism used in Models TRK-6700, TRK-6701, etc.  
Refer to respective service manual for other items.

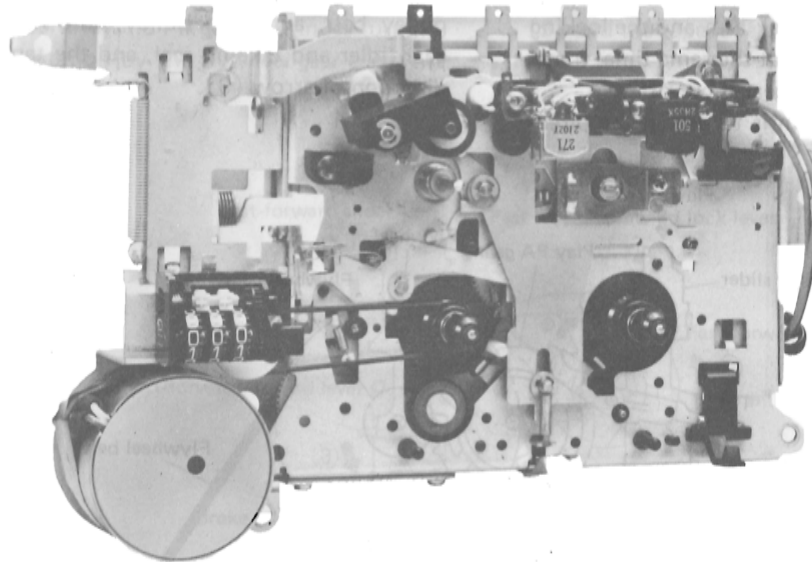

### CONTENTS

DESCRIPTION OF NEW MECHANISM .....	2
1. Play mode .....	2
2. Fast-forward mode .....	3
3. Rewind mode .....	4
4. 3-tune selection mode (when tune selection mechanism is provided) .....	4
5. Record mode .....	5
6. Auto-stop mechanism .....	5
DISASSEMBLY .....	7
1. Flywheel .....	7
2. Solenoid (when tune selection mechanism is provided) .....	7
3. Lock plate .....	7
4. Reel holder ass'y .....	7
LUBRICATION .....	10
INSPECTION OF MECHANISM .....	10
EXPLODED VIEW .....	11
REPLACEMENT PARTS LIST .....	13

SPECIFICATIONS AND PARTS ARE SUBJECT TO CHANGE FOR IMPROVEMENT

## GT-5000 Mechanism

Jan. 1983

TOKAI WORKS

## DESCRIPTION OF NEW MECHANISM

## 1. Play mode

When the play button is pressed, the play slider is pushed up in the direction of arrow ①, so the brake plate is depressed to set S8 (motor switch) to ON and simultaneously it is released from the reel and the brake is released. The play lock arm is turned in the direction of arrow ② by the projection of the play slider and releases locking of the play PA gear, so the play PA gear turns a little in the direction of arrow ③ and engages with the flywheel gear. The flywheel turns in the direction of arrow ④, so the play PA gear continues to turn in the direction of arrow ③ and then it is locked by the play lock arm and the locking projection of the play PA gear, and at the same time, transmission of rotation by the flywheel gear is cut off.

In the meantime, the operation arm is turned in the direc-

tion of arrow ⑤ by the rotation of the operation arm operating cam of the play PA gear, and by this, the head plate coupled with the operation arm is depressed in the direction of arrow ⑥. When the head plate is depressed, the pressure roller turns in the direction of arrow ⑦ and is compressed against the capstan, and at the same time the idler is turned in the direction of arrow ⑧ and is compressed against the take-up reel. The idler gear and the auto-stop pulley gear are engaged with each other, and motor rotation is transmitted to the flywheel, auto-stop pulley belt, auto-stop pulley, auto-stop pulley gear, idler gear, idler and take-up reel, and the tape is taken up in the direction of arrow ⑨.

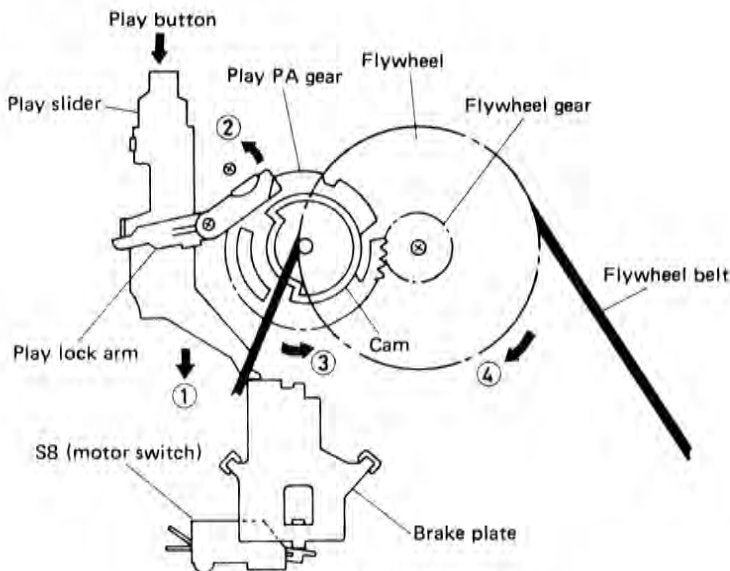

Fig. 1 Play mode (initial stage)

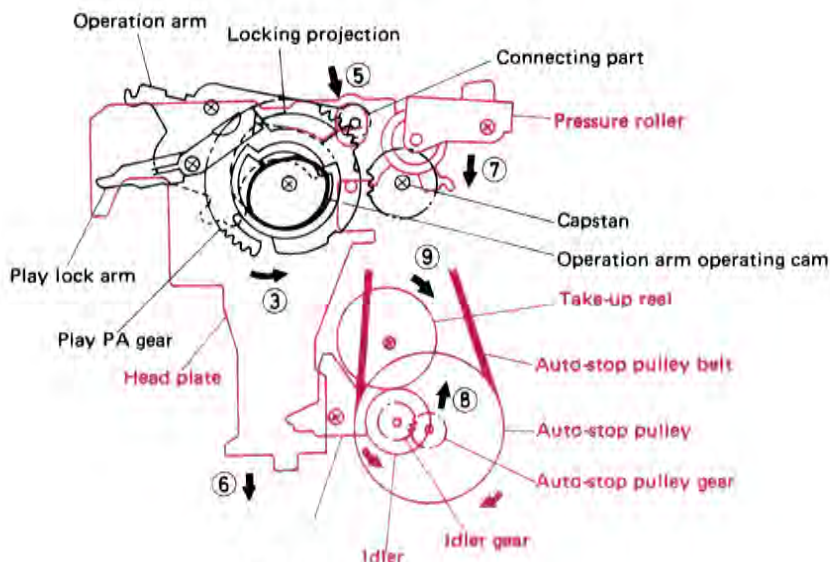

Fig. 2 Play mode

## 2. Fast-forward mode

When the fast-forward button is pressed, the fast-forward slider is depressed in the direction of arrow ①, so the brake plate is depressed and brake is released, and at the same time the fast-forward gear arm turns in the direction of arrow ② and is engaged with the take-up reel gear. Meanwhile, the fast-forward/rewind lever is turned in the direction of arrow ③ by the fast-forward slider and turns the fast-forward/rewind lock lever in the direction of arrow ④. Locking of the fast-forward/rewind PA gear is released by rotation of the fast-forward/rewind lock lever, so the fast-forward/rewind PA gear turns a little in the direction of arrow ⑤ and is engaged with the flywheel. The flywheel turns, so the fast-forward/rewind PA gear continues turning, and transmission of rotation by the flywheel gear is cut off

when the locking projection touches the fast-forward/rewind lock lever and is locked. At the same time, the fast-forward/rewind operation arm is turned in the direction of arrow ⑥ by rotation of the operating cam of the fast-forward/rewind PA gear, so the intermediate pulley arm is turned in the direction of arrow ⑦, and the intermediate pulley gear and the gear of the fast-forward gear arm are engaged with each other.

As the intermediate pulley is turning in the direction of arrow ⑧, rotation is transmitted to the intermediate pulley, gear, fast-forward gear arm gear and take-up reel gear, and the take-up reel turns in the direction of arrow ⑨ and the tape is fast-forwarded.

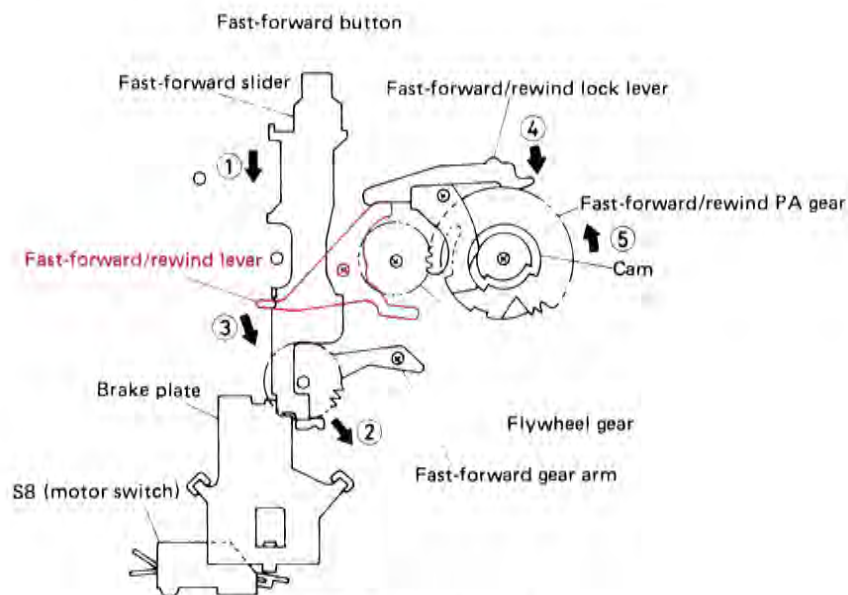

Fig. 3 Fast-forward mode (initial stage)

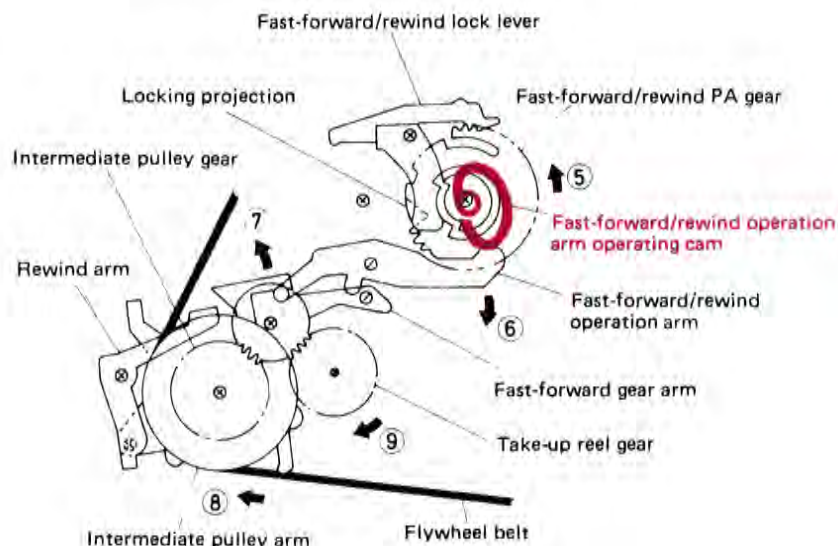

Fig. 4 Fast-forward mode

### 3. Rewind mode

When the rewind button is pressed, the rewind slider is depressed in the direction of arrow ①, so the brake plate is depressed and brake is released, and at the same time, the fast-forward/rewind operation arm is turned in the direction of arrow ② by rotation of the fast-forward/rewind lock lever. The rewind arm slides in the direction of arrow ④ due to the coupling pin of the rewind slider to the extent that the intermediate pulley gear and supply reel gear engage

with each other, the intermediate pulley arm turns in the direction of arrow ③ and gears are engaged with each other, before the intermediate pulley arm is turned in the direction of arrow ③ by rotation of the fast-forward/rewind operation arm.

Rotation of the intermediate pulley is transmitted to the supply reel gear via the intermediate pulley gear, so the supply reel turns in the direction of arrow ⑤ and tape is rewound.

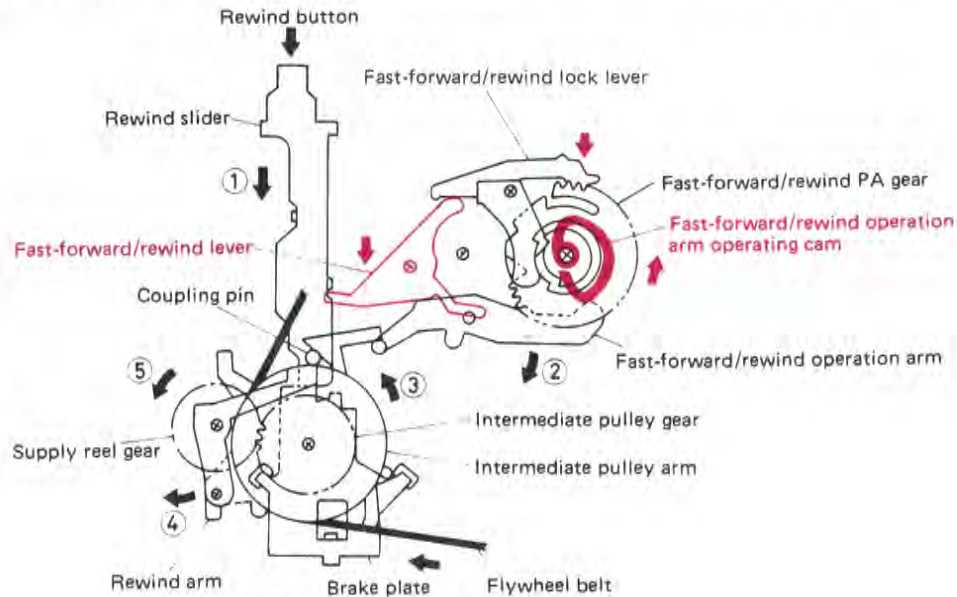

Fig. 5 Rewind mode

### 4. 3-tune selection mode (when tune selection mechanism is provided)

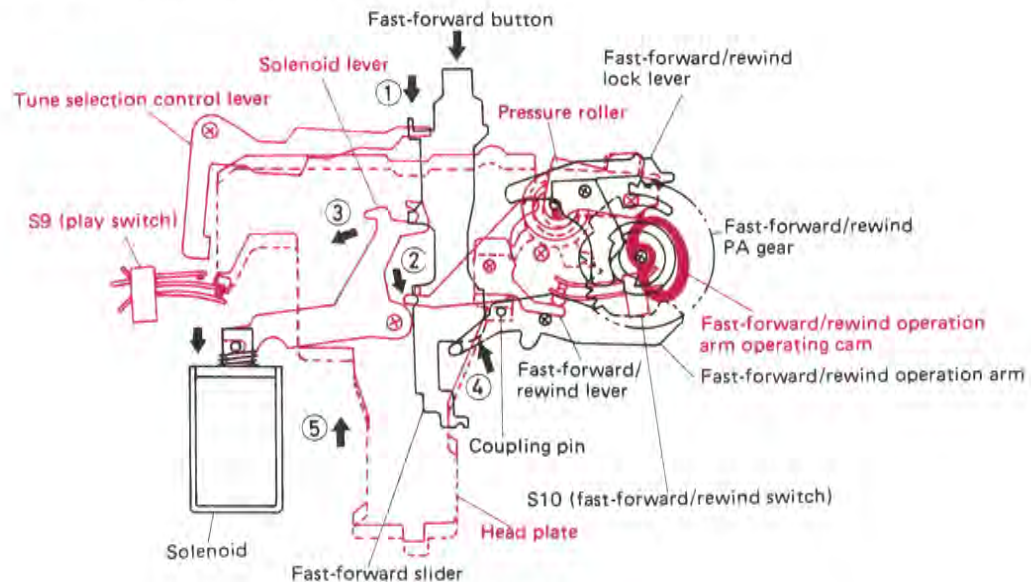

Fig. 6 3-tune selection mode

When the fast-forward button is pressed in the play mode, the fast-forward slider is depressed in the direction of arrow ① and the fast-forward/rewind lever turns in the direction

of arrow ②, so S10 (fast-forward/rewind switch) is closed and the solenoid operates. When the solenoid operates, the solenoid lever turns in the direction of arrow ③ to lock

the fast-forward slider. At the same time, the fast-forward/rewind operation arm is turned in the direction of arrow ④ by the rotation of the fast-forward/rewind operation arm operating cam, the same as in the fast-forward mode, so the fast-forward mode is entered, and at the same time, the head plate is pushed up in the direction of arrow ⑤ by the coupling pin of the fast-forward/rewind operation

arm. Because of this, the pressure roller is released from the capstan and the unit enters the tune selection mode. Rewind tune selection is done in the same way. The tune selection control lever prevents the tune selection operation during recording; when the fast-forward (or rewind) button is pressed during recording, it cannot be pushed in because rotation is controlled by the record slider.

**5. Record mode**

When the record button is pressed with a cassette loaded, the record slider is depressed in the direction of arrow ① and the record arm is turned in the direction of arrow ② by the projection of the record slider. At the same time, the play slider is also depressed by the projection of the record slider, so the same operation as in the play mode is performed. (Refer to "1. Play mode" on Page 2).

The record arm is pushed out in the direction of arrow ③ by the tension of the spring, so it is connected with the concave (∩) section of the operation arm but slides due to the rotation of the operation arm in the direction of arrow ④ turning the record lever in the direction of arrow ⑤. The record/play switch connected via the record spring is changed over to the recording side by the rotation of the record lever and the unit enters the record mode.

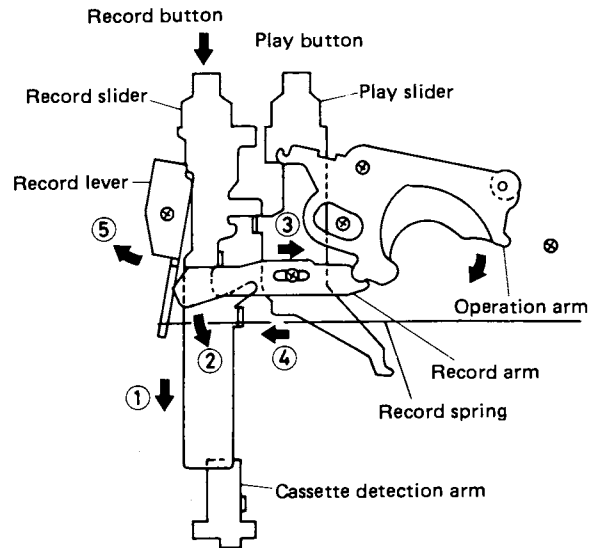

Fig. 7 Record mode

**6. Auto-stop mechanism**

Motor rotation is transmitted to the auto-stop pulley via the belt, and then rotation in the direction of the arrow is transmitted to the auto-stop pulley gear and auto-stop cam gear. The floating arm repeats movement by the rotation of the cam of the auto-stop cam gear but the floating lever is controlled by the rotation of the projection of the reel.

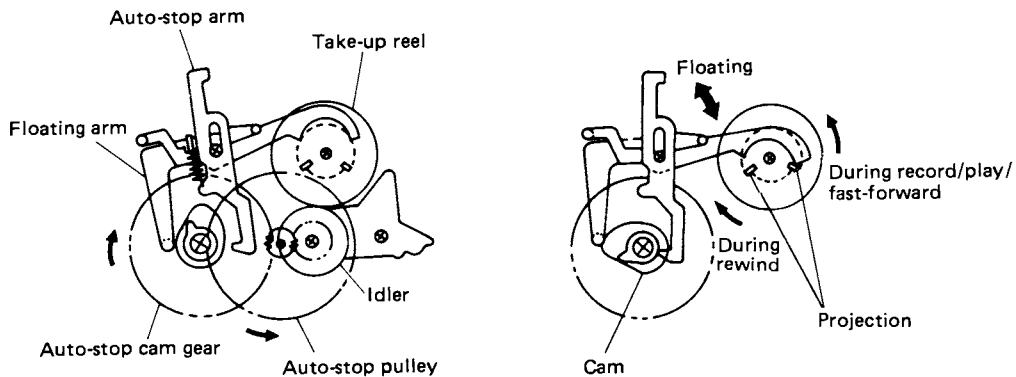

Fig. 8 Floating mode

When the tape is taken up and the take-up reel stops turning, there is no rotation force of the reel projection and the floating arm is released from control. The floating arm continues rotation in the direction of arrow ① until it touches both projections of the reel, so the auto-stop arm is turned in the direction of arrow ② by the tension of the spring and engages with the projection of the auto-stop cam gear and the projection of the stop slider. The auto-stop cam gear continues to rotate in the direction of arrow ③, so the auto-stop arm is drawn in the direction of arrow ④. As a result, the stop slider is also drawn downward, so all operation sliders are released from locking to enter the stop mode.

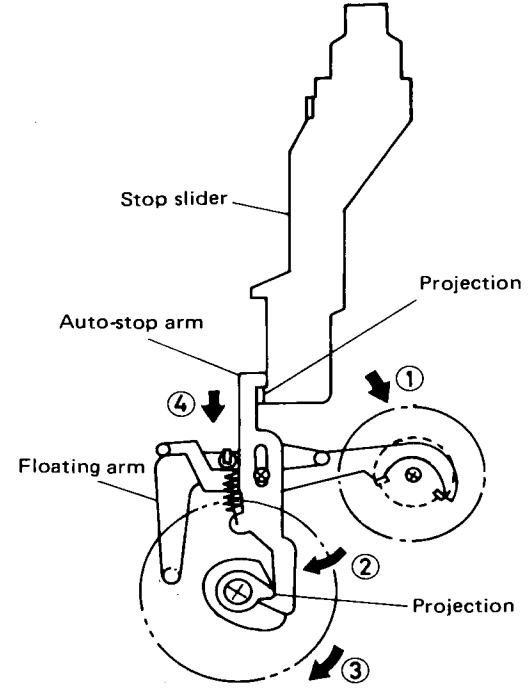

Fig. 9 Auto-stop operation

● Controlling auto-stop operation during pause

When the pause button is pressed, the pause slider is depressed in the direction of arrow ①, so the auto-stop control lever is turned in the direction of arrow ②. The auto-stop arm remains in the position turned in the direction of arrow ③ by this auto-stop control lever, so the auto-stop arm does not operate when the reel stops and the floating arm turns.

The auto-stop control arm returns to its original position when the pause mode is released, so the auto-stop arm is released from control and enters the auto-stop operation mode.

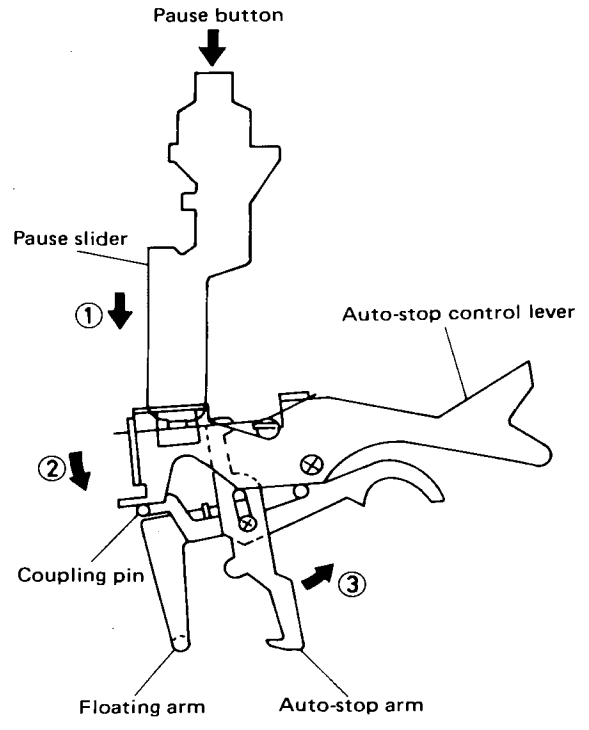
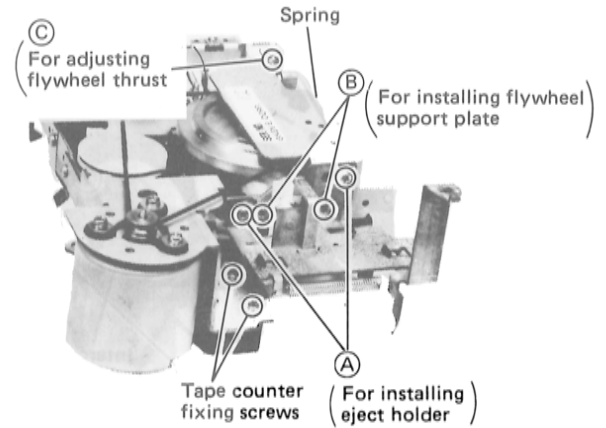

Fig. 10 Controlling auto-stop operation during pause

## DISASSEMBLY

## 1. Flywheel

Remove 2 eject holder fixing screws (A), then remove 2 flywheel support plate fixing screws (B), one flywheel thrust adjusting screw (C) and spring, to remove the flywheel support plate.



## 2. Solenoid (when tune selection mechanism is provided)

Remove one solenoid holder fixing screw (D).

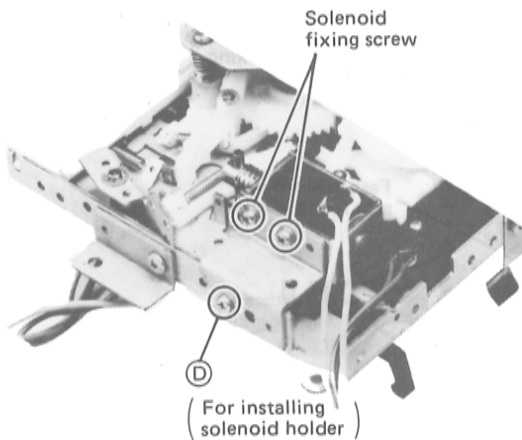

## 3. Lock plate

Open 90° in the direction of the arrow, then lift the left side of the lock plate and pull it to the left to remove it.

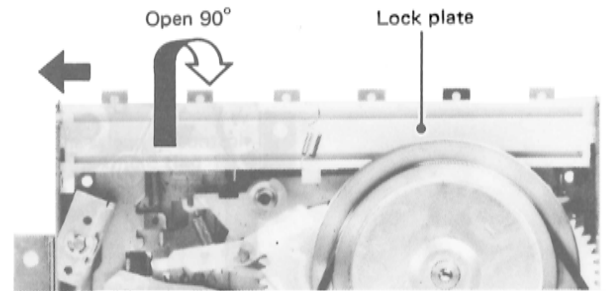

## 4. Reel holder ass'y

Remove 4 fixing screws (E) and the spring. Check the coupling positions between the intermediate pulley arm and the fast-forward/rewind operation arm,

the auto-stop control lever and the floating arm, the brake plate and SB (motor switch) before installing the reel holder ass'y.

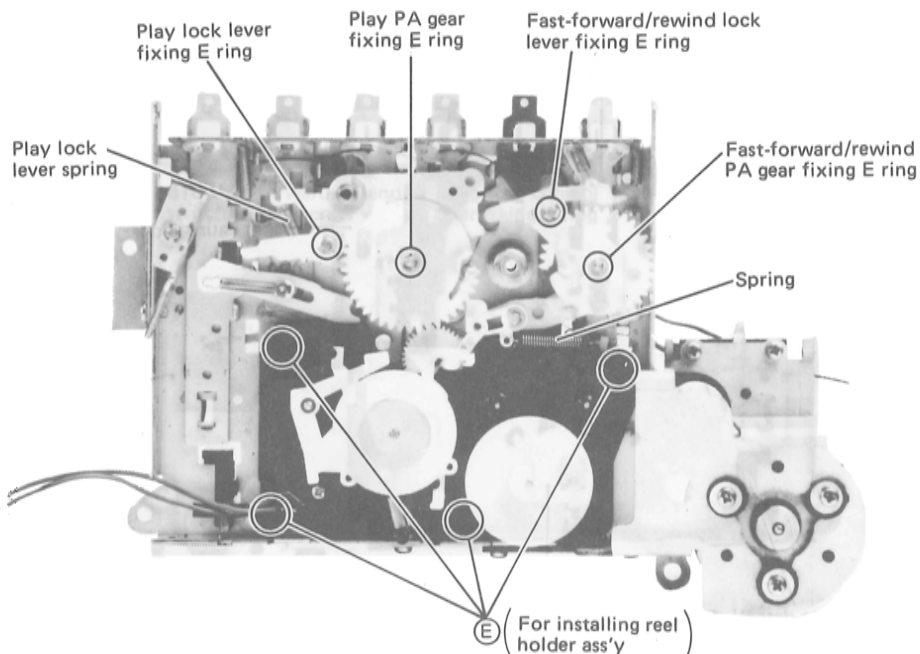

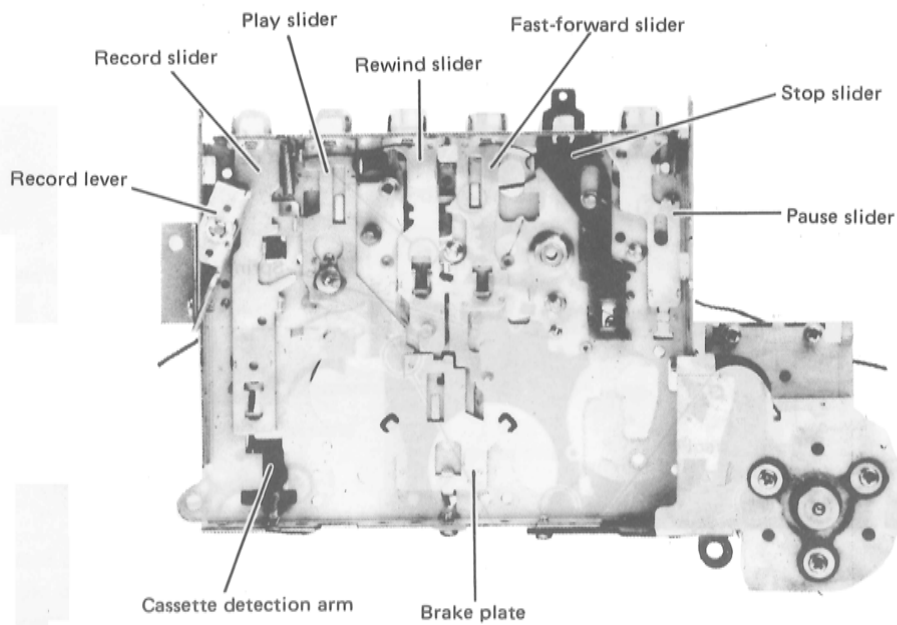
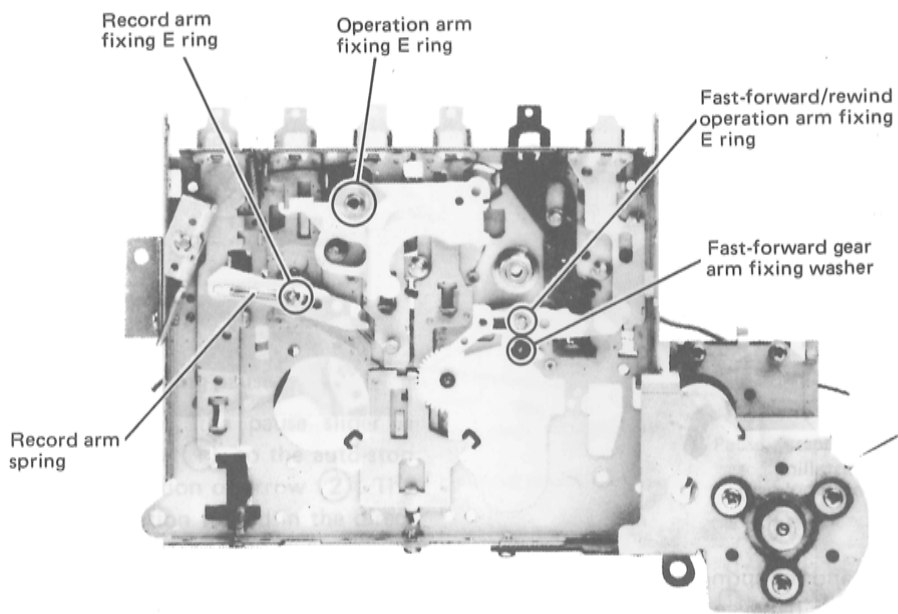
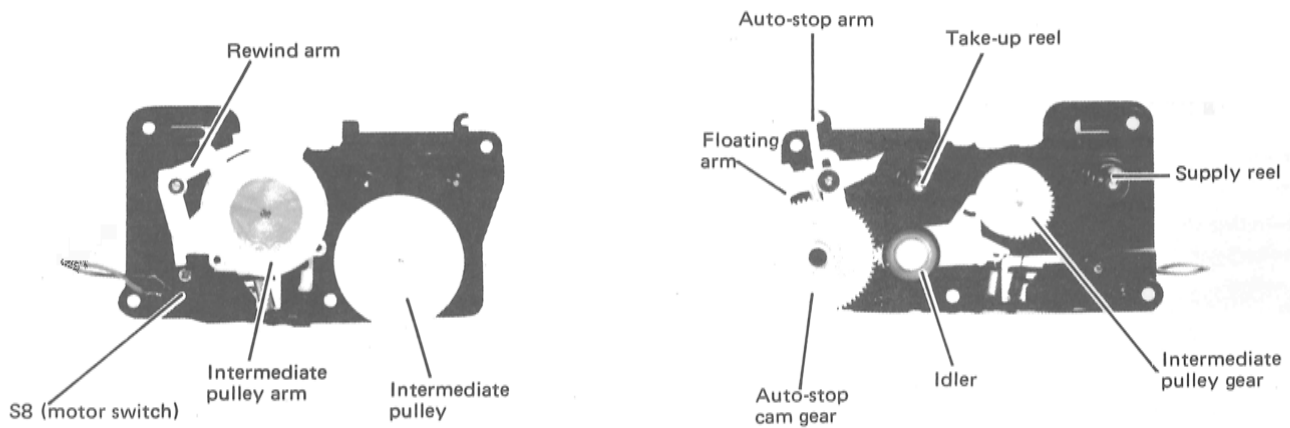



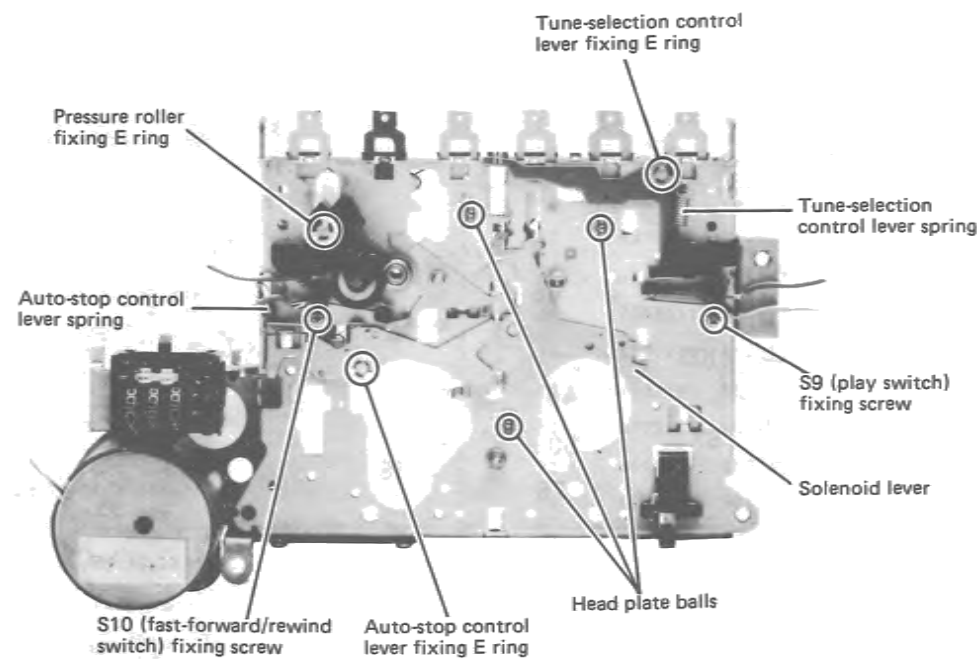
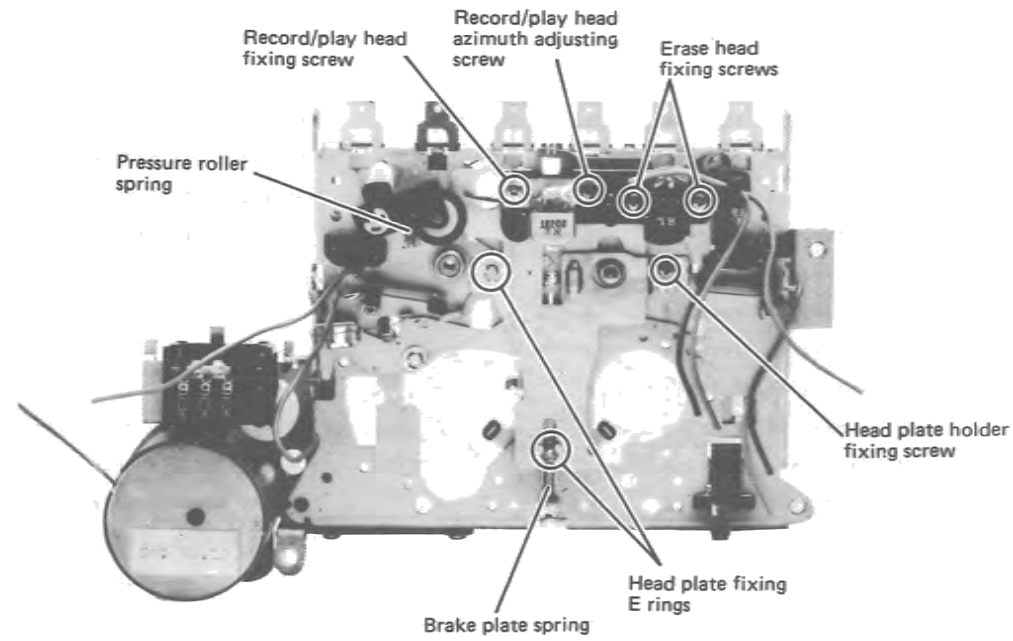

LUBRICATION

Lubricate one or two drops of oil to rotating point or lubricate grease to sliding point. Lubricate the respective parts listed once every 1000 hours or once a year under normal conditions of use. Avoid oiling them excessively, or rotation may become irregular because of oil splashes.

Lubrication		Oil or Grease
Spring resonance prevention		Floil (GB-TS-1)
Rotary section	Metal and metal	Pan motor oil (10W-40)
	Mold and metal	Sonic slider oil (# 1600)
Sliding section	Metal and metal	Hitasol (MO-138)
	Mold and mold Mold and metal	White grease (FL-LUBE-A)

INSPECTION OF MECHANISM

Item #	Inspection item	Reference value	Remarks	
1	Pressure of pressure roller	300 ~ 500 g		
2	Take-up torque	35 ~ 75 g.cm	Measure using a cassette type torque gauge	
3	Fast-forward/rewind torque	Fast-forward	90 ~ 150 g.cm	Measure using a cassette type torque gauge
		Rewind	90 ~ 150 g.cm	
4	Back tension torque	Supply side	1.5 ~ 5.5 g.cm	Measure using a cassette type torque gauge
		Take-up side	2.0 ~ 6.5 g.cm	Measure using a fan type tension gauge with the counter belt applied
5	Brake torque	15 g.cm or more	Measure in the stop mode	
6	Button operation force	Play button	0.4 kg or less	Measure with the button completely pushed in.
		Fast-forward button	0.5 kg or less	
		Rewind button	0.6 kg or less	
		Fast-forward button (tune selection)	0.5 kg or less	Measure with the button pressed in the play mode.
		Rewind button (tune selection)	0.6 kg or less	
		Stop button	0.4 kg or less	Measure without the record/play select switch.
		Record button	0.45 kg or less	
Pause button	0.45 kg or less			
7	Flywheel thrust gap	0.05 ~ 0.3 mm		

EXPLODED VIEW

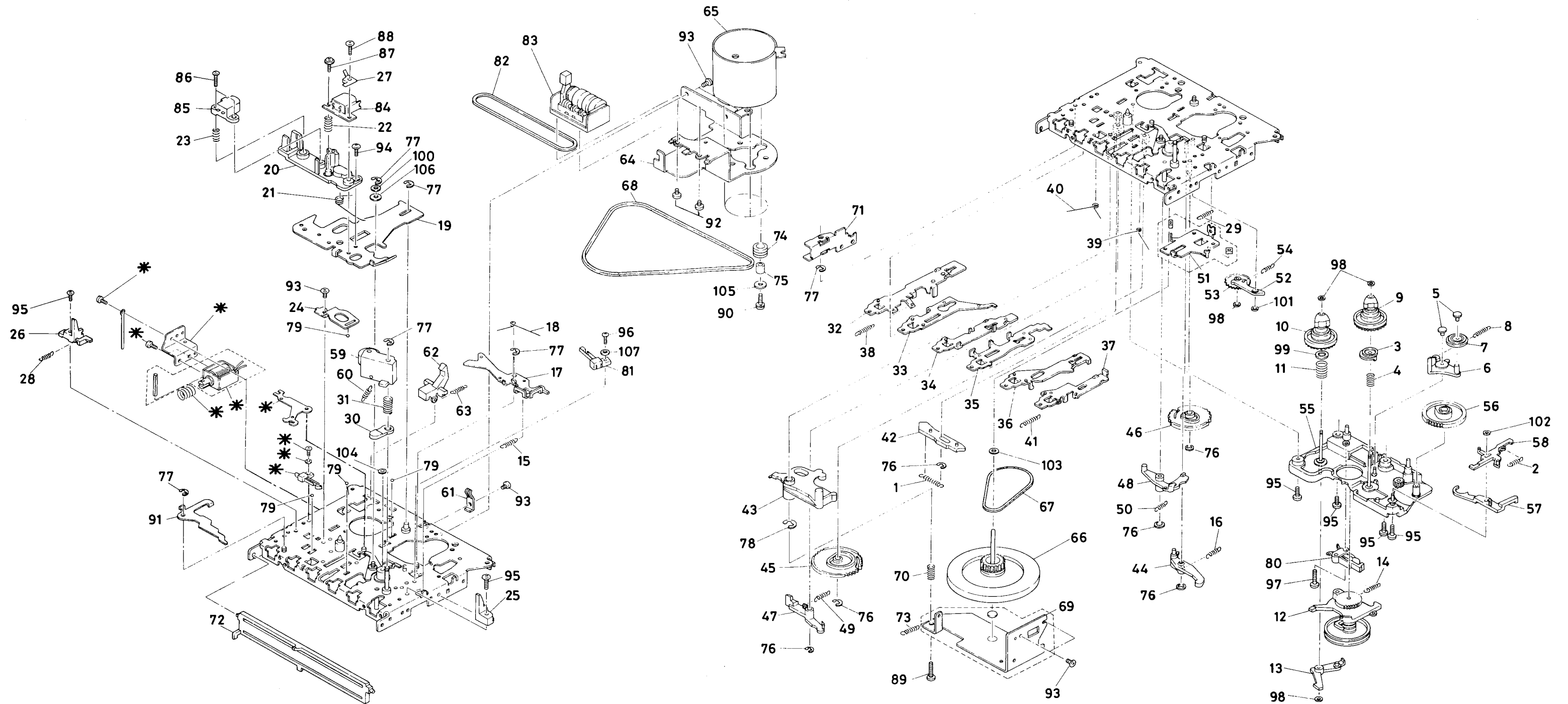

Parts marked \* : When tune selection mechanism is provided.  
(Refer to respective service manual.)

Note: Components marked without numbers in this drawing are not specified as replacement parts.

## REPLACEMENT PARTS LIST

SYMBOL-NO	P-NO	DESCRIPTION	SYMBOL-NO	P-NO	DESCRIPTION
MECHANISM (GT-5000)			44	6775361	FF/REWIND ARM
1	6543251	SPRING FOR RECORD ARM	45	6432851	PLAY PA GEAR
2	6543401	SPRING FOR AUTO ARM	46	6432861	FF/REWIND PA GEAR
3	6775281	AUTO CLUTCH ASSEMBLY	47	6775321	PLAY LOCK ARM
4	6521191	TENSION SPRING	48	6775341	FF/REWIND LOCK ARM
5	6794491	BUSH	49	6543391	SPRING FOR FUNCTION ARM
6	6775271	PLAY ARM	50	6543241	SPRING FOR FF/REWIND LOCK ARM
7	6382241	PLAY IDLER	51	7353291	BRAKE PLATE ASSEMBLY
8	6543231	SPRING FOR PLAY ARM	52	6775301	FF GEAR ARM
9	6432831	TAKE UP REEL ASSEMBLY	53	6432821	FF GEAR
10	6432841	SUPPLY REEL ASSEMBLY	54	6543311	SPRING FOR FF GEAR
11	6521231	BACK TENSION SPRING	55	6775261	TURNTABLE HOLDER ASSEMBLY
12	6775251	FR PULLEY ARM ASSEMBLY	56	6432811	AUTO GEAR
13	6775291	REWIND ARM	57	6775311	SENER ARM
14	6543321	SPRING FOR FR PULLEY ARM	58	6775431	AUTO STOP ARM
15	6543281	SPRING FOR AUTO LOCK ARM	59	6775231	PRESSURE ROLLER ARM ASSEMBLY
16	6543421	SPRING FOR FF/REWIND ARM	60	6543271	SPRING FOR PRESSURE ROLLER ARM
17	7353221	AUTO STOP PREVENTION LEVER	61	7353211	CASSETTE HOLDER
18	6543741	SPRING FOR AUTO STOP PREVENTION LEVER	62	6775241	RECORD PREVENTION ARM
19	7130031	HEAD PLATE	63	6543291	SPRING FOR RECORD PREVENTION ARM
20	6775411	HEAD BASE	64	7350491	MOTOR BRACKET
21	6548711	HEAD BASE SPRING	65	6428571	DC MOTOR ASSEMBLY
22	6521251	HEAD SPRING	66	6374351	FLYWHEEL
23	6521221	HEAD SPRING	67	6355831	BELT
24	7353201	HEAD PLATE HOLDER	68	6355811	BELT
25	6775401	CASSETTE GUIDE(R)	69	7353311	FLYWHEEL BRACKET ASSEMBLY
26	6775391	CASSETTE GUIDE(L)	70	6521211	ADJUST SPRING
27	7351741	EARTH PLATE	71	7353261	RECORD LEVER
28	6543221	SPRING	72	6775381	LOCK PLATE
29	6543381	BRAKE SPRING	73	6543411	SPRING FOR LOCK PLATE
30	6775371	PAUSE CAM	74	6590961	MOTOR CUSHION
31	6521201	SPRING FOR PAUSE CAM	75	7353181	MOTOR RING
32	7353131	RECORD SLIDER	76	7778395	E RING
33	7353141	PLAY SLIDER	77	7774641	E RING-2.5MMD
34	7353101	REWIND SLIDER ASSEMBLY	78	7230903	E RING - 4MMD
35	7353251	FF SLIDER	79	0948492	BALL - 2MMD
36	7353121	STOP SLIDER	80	5603671	LEAF SWITCH (SB, MOTOR SWITCH)
37	7353111	PAUSE SLIDER ASSEMBLY	81	5603651	LEAF SWITCH
38	6543261	SPRING FOR RECORD SLIDER	82	6355821	COUNTER BELT
39	6548731	LEVER SPRING	83	5559611	COUNTER
40	6548721	LEVER SPRING	84	5449271	RECORD PLAYBACK HEAD
41	6543301	SPRING FOR PAUSE SLIDER	85	5445501	ERASE HEAD
42	6775331	RECORD ARM	86	7782901	BIND SCREW-2MMDX9.5MM
43	6775351	FUNCTION ARM	87	7782911	PAN HEAD SCREW WITH LOCKING WASHER
			88	8741108	BIND SCREW-2MMDx8MM

SYMBOL-NO	P-NO	DESCRIPTION	SYMBOL-NO	P-NO	DESCRIPTION
89	0741310	BIND SCREW-2.6MMDX10MM	99	7788551	REEL WASHER
90	8650908	SCREW WITH SPRING WASHER-2.6MMDX8MM	100	7788531	NYLON WASHER
91	7353281	FR LOCK ARM	101	7786211	POLYESTER WASHER
92	8781335	TAPPING SCREW 2.6MMD X 5MM	102	7786624	POLY SLIDER WASHER
93	0671304	DT SCREW-2.6MMDX4MM	103	7787418	POLY SLIDER WASHER
94	0678304	DT SCREW-2.6MMDX4MM(BLACK)	104	7786623	POLY SLIDER WASHER
95	0678308	DT SCREW-2.6MMDX8MM(BLACK)	105	8811113	WASHER - 2.6MMD
96	7780883	TAPPING SCREW-2MMDX6MM	106	8811114	3D WASHER
97	7780916	BIND TAPPING SCREW-2MMDX12MM	107	8812111	WASHER-2MMD
98	7788541	WASHER			



# HITACHI

## HITACHI SALES CORPORATION OF AMERICA

### Eastern Regional Office

1200 Wall Street West, Lyndhurst, New Jersey 07071,  
U.S.A.

Te. 201-935-8980

### Mid-Western Regional Office

1400 Morse Ave., Elk Grove Village, Ill. 60007, U.S.A.  
Tel. 312-593-1550

### Southern Regional Office

510 Plaza Drive, College Park, Georgia 30349, U.S.A.  
Tel. 404-763-0360

### Western Regional Office

401 West Artesia Boulevard, Compton, California 90220  
U.S.A.

Tel. 213-537-8383

## HITACHI SALES CORPORATION OF HAWAII, INC.

3219 Koapaka Street, Honolulu, Hawaii 96819, U.S.A.  
Tel. 808-836-3621

## HITACHI (HSC) CANADA INC.

3300 Trans-Canada Highway, Pointe Claire, Quebec,  
H9R1B1, Canada  
Tel. 514-697-9150

## HITACHI SALES EUROPA GmbH

Postfach 801060 Rungedamm 2, 2050 Hamburg 80,  
West Germany  
Tel. 040-734 11-0

## HITACHI SALES (U.K.) Ltd.

Hitachi House, Station Road, Hayes, Middlesex UB3  
4DR, England  
Tel. 01-848-8787

## HITACHI SALES SCANDINAVIA AB

Rissneleden 8, Box 7138, 172-07 Sundbyberg, Sweden  
Tel. 09-98 52 80

## HITACHI SALES NORWAY A/S

Oerebekk 1620, Gressvik, P.O. Box 46, N-1601,  
Fredrikstad, Norway  
Tel. 032-28255

## SUOMEN HITACHI OY

Takojankatsu 5, 15800 Lahti 80, Finland  
Tel. Lahti 44 241

## HITACHI SALES A/S

Kuldysen 13, DK-2630, Taastrup, Denmark  
Tel. 02-999200

## HITACHI SALES A.G.

Bahnhofstrasse, 19, 5600 Lenzburg, Switzerland  
Tel. 064-513621

## HITACHI SALES WARENHANDLES GMBH

A-1180/Wien, Kreuzgasse 27, Austria  
Tel. 0222-439367

## HITACHI-FRANCE S.A.

95-101 Rue Charles Michels,  
93200 SAINT-DENIS, France  
Tel. 821 6015

## HITACHI SALES ITALIANA, S.P.A.

Via Cristoford Colombo 49, Trezzano sul naviglio  
(Milano), Italy  
Tel. 02-44 59 031

## HITACHI SALES BELGIUM S.A.

56, Chaussee de Namur B-1400 Nivelles, Belgium  
Tel. (003267) 227181

## HITACHI SALES IBERICA, S.A.

Gran Via Carlos Tercero, 101, 1-1, Barcelona-28,  
Spain  
Tel. 330-8652

## HITACHI SALES AUSTRALIA Pty Ltd.

153 Keys Road, Moorabbin, Victoria 3189 Australia  
Tel. 555-8722

## HITACHI Ltd. TOKYO JAPAN

Head Office: THE HITACHI ATAGO BLDG.

No. 15-12, 2-Chome Nishi-Shinbashi  
Minato-Ku, Tokyo 105, Japan  
Tel. Tokyo (03) 502-2111